

Product Outline

- High reliability DC/DC converter transformers.
- Ideally used in Electric compressor for Car Air-conditioner, Converter on ECU, BMS, LED head light driving, IGBT and other electronic devices.
- Operating temperature range(Including self temperature rise):-40°C to +125°C.
- Custom design is also available.
- RoHS Compliant.

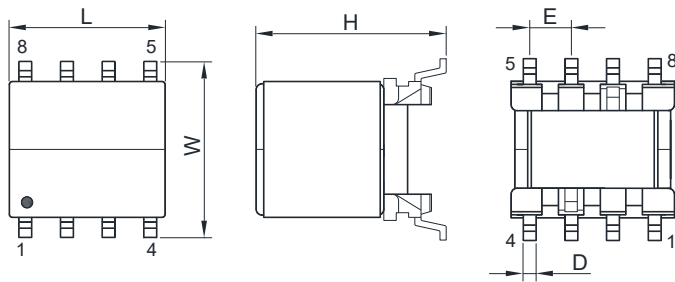

Dimensions



Schematics Recommended Land Patterns

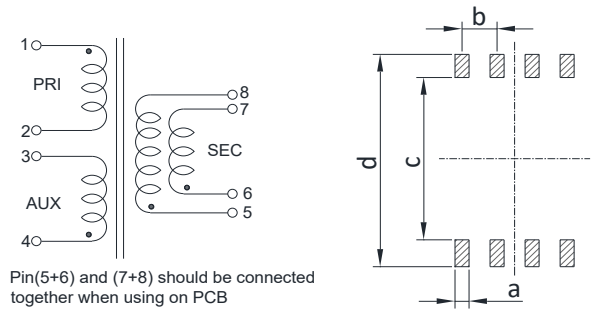

Unit: mm

Type	L	W	H	D	E	a	b	c	d	Packaging (pcs/reel)
TEP0710	9.8 Max.	9.0 Max.	10.5 Max.	0.7	2.5	1.2	2.5	6.0	10.2	300

Dimensions without tolerance are typical.

Electrical Characteristics(at 25°C)

Part Number	Inductance(uH) 100kHz,0.1V	Inductance(uH) 100kHz,0.1V,0.5A	LK(uH) 100kHz,0.1V	DCR (mΩ)	Turns Ratio	Hi-Pot 50/60Hz, 1mA,60S		SRF (MHz)
	PRI	PRI	PRI (Short others)	PRI	PRI:SEC:AUX	PRI,AUX-SEC	COIL-CORE	PRI
TEP0710-A001	115±10%	98 Min.	1.2 Max.	520 Max.	1: 0.4:0.6	AC 1500V	AC 1500V	1.5 Min.